

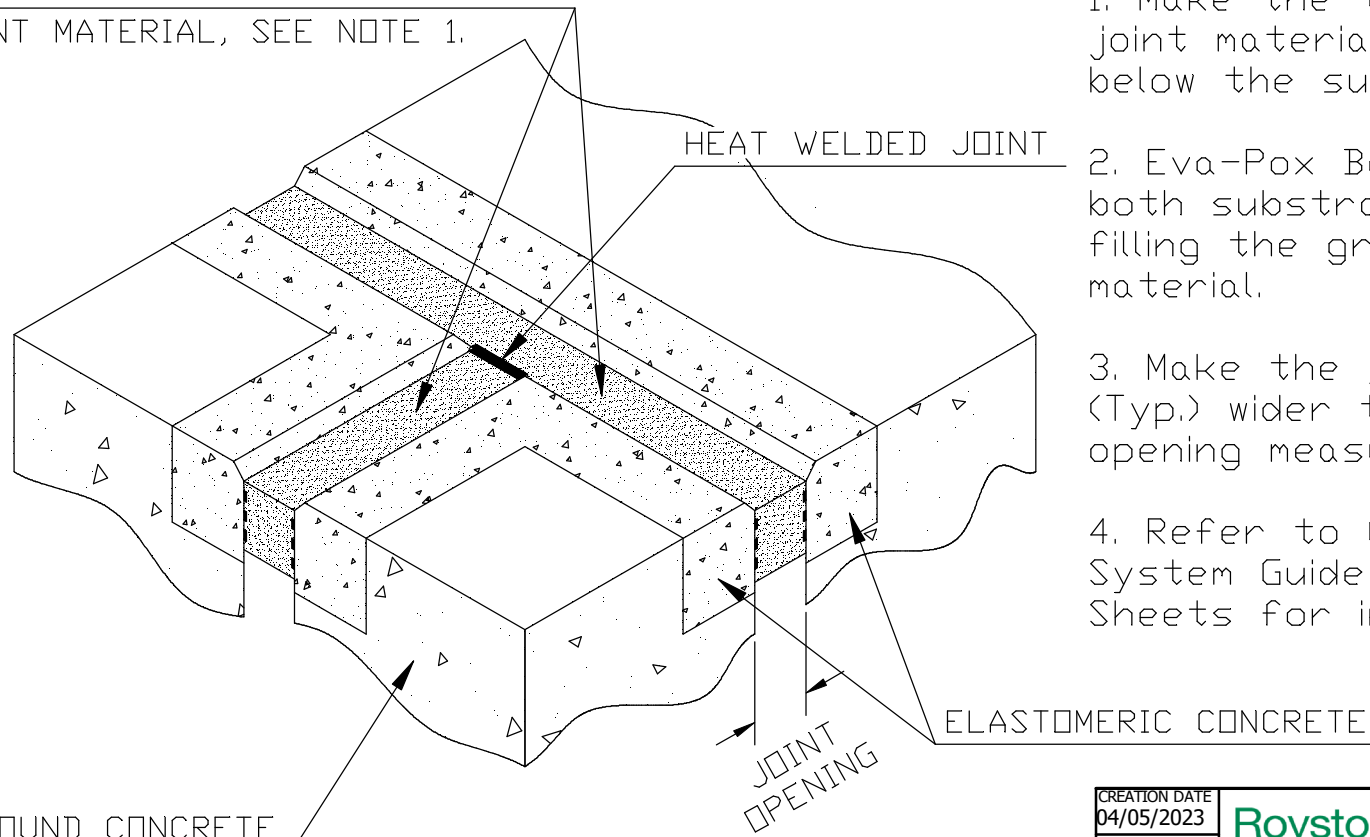

PHYZITE 380/METAZEAL EXPANSION  
JOINT MATERIAL, SEE NOTE 1.



NOTES

1. Make the top of the expansion joint material from 1/8" to 1/4" below the surface.
2. Eva-Pox Bonder #1 applied to both substrate surfaces and filling the grooves on the joint material.
3. Make the joint material 25% (Typ.) wider than the joint opening measured at 68°F (20°C)
4. Refer to CEVA Expansion Joint System Guide and Technical Data Sheets for instructions.

CREATION DATE 04/05/2023	 		
CHECKED DATE 04/05/2023	TITLE CEVA EXPANSION JOINT SYSTEM WITH 90 DEGREE HEAT WELD CONNECTION		
DRAWN MCCALL	SIZE B	DWG NO EXJ-2	REV
SCALE NONE	SHEET 1 OF 1		